

**INSTALLATION  
INSTRUCTIONS**

Accessory  
**TRAILER HITCH**

Application  
**2016 MDX**

Publications No.  
**VERSION 2**  
Issue Date  
**JAN 2015**

**PARTS LIST**

**Trailer Hitch Kit  
P/N 08L92-TZ5-202**

Trailer hitch

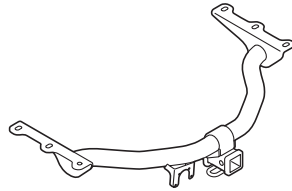

Ball mount

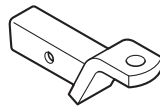

Trailer hitch cover

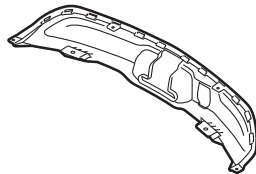

Hitch pin



Hitch pin clip



Receiver cover



6 Flange bolts, 14 x 40 mm

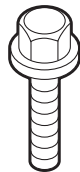

2 Washer-bolts, 6 x 14 mm



Caution label

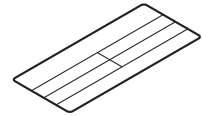

**Trailer Hitch Harness Kit  
P/N 08L91-TZ5-201**

Control unit

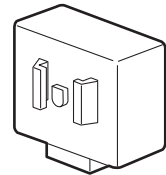

Control unit bracket

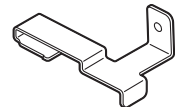

Control unit harness

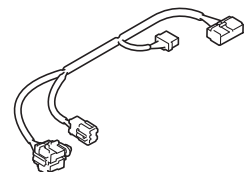

Socket harness

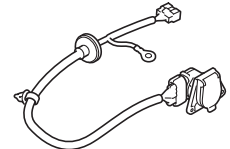

2 Blade fuses, 7.5A

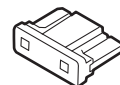

2 Blade fuses, 20A

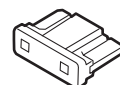

Block fuse, 20A



2 Relays

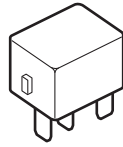

5 Wire ties

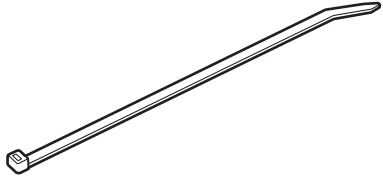

Flange bolt, 6 x 16 mm



Shoulder bolt, 6 x 19 mm



2 Flange nuts



Urethane tape

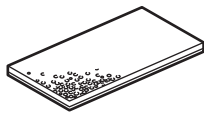

Subharness kit

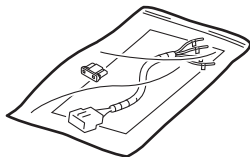

Accessory User's Information Manual

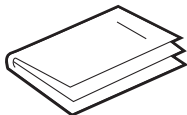

## Accessory Front Towing Grille P/N 71103-TZ6-A00

Front bumper middle grille

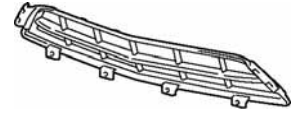

### TOOLS AND SUPPLIES REQUIRED

10 mm Open end wrench

Ratchet

Torque wrench

10 mm, 17 mm, and 19 mm Sockets

Phillips screwdriver

Flat-tip screwdriver

Pushpin

Ruler

Scissors

Utility knife

File

Diagonal cutters

Isopropyl alcohol

Shop towel

*The following tool is available through the Honda Tool and Equipment Program. On the iN, click on: Service > Service Bay > Tool and Equipment Program, then enter the number under "Search". Or, call 888-424-6857.*

- Plastic Trim Tool (T/N SILTRIMTL10)

## Illustration of the Trailer Hitch Installed on the Vehicle

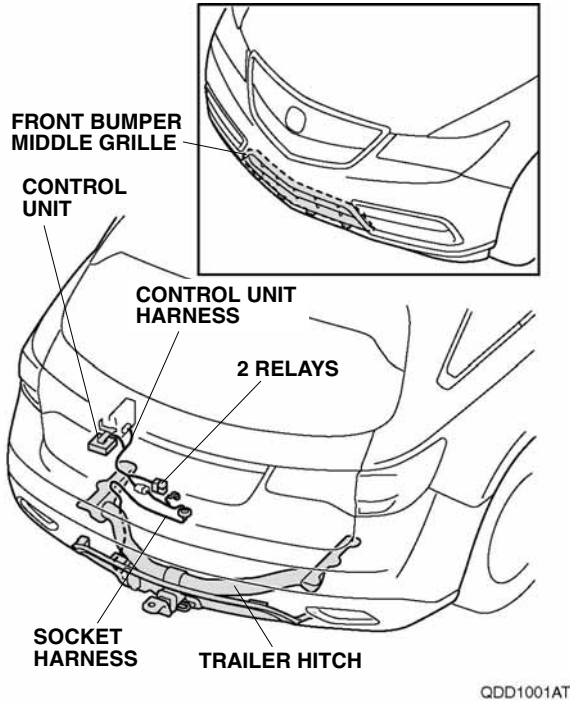

## INSTALLATION

**Client Information:** The information in this installation instruction is intended for use only by skilled technicians who have the proper tools, equipment, and training to correctly and safely add equipment to your vehicle. These procedures should not be attempted by “do-it-yourselfers.”

### Removing the Vehicle Parts

1. Disconnect the negative cable:
  - Wrap a shop towel around the hood latch.

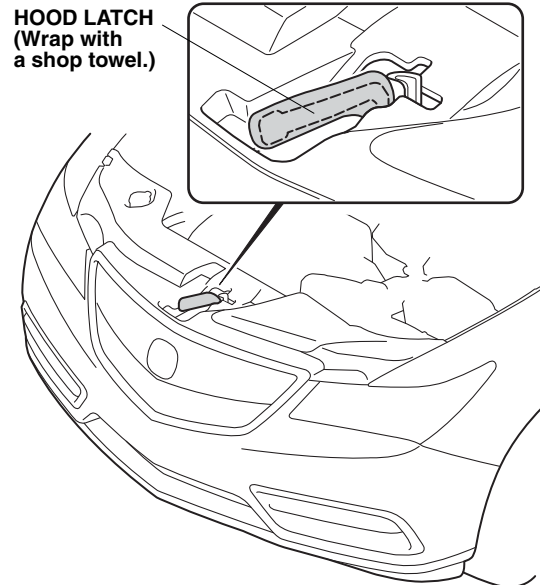

- Remove the front bulkhead cover.

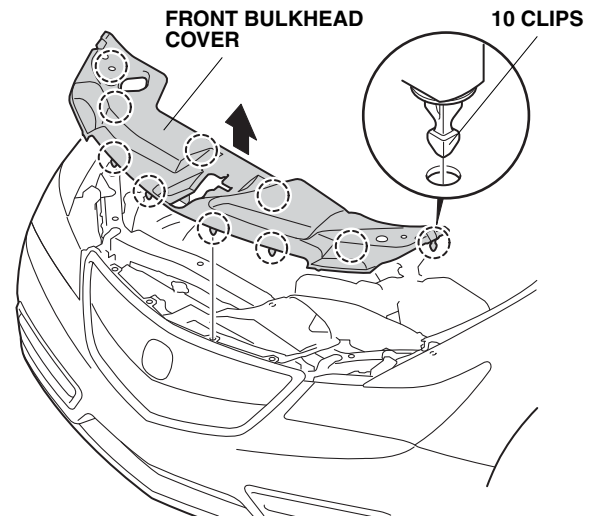

- Remove the intake air tube.
- Disconnect the negative cable from the battery.

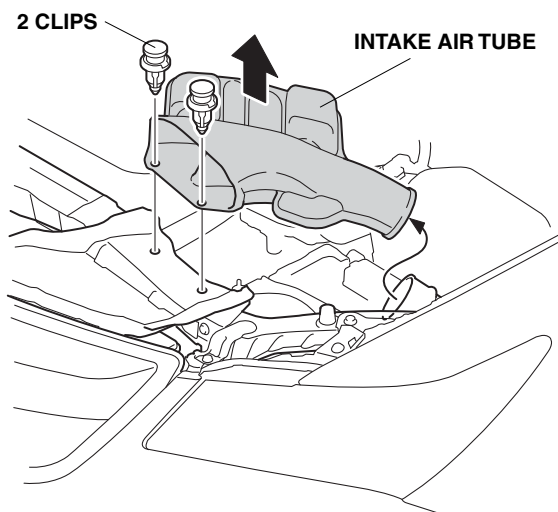

QBN1504BK

2. Remove the splash shield and fold down the front bumper skid trim.

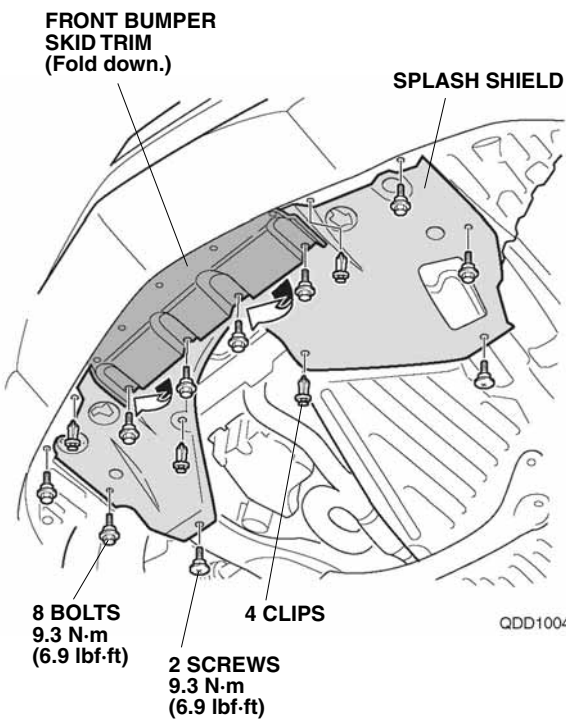

QDD1004AT

3. Remove the lower air guide.

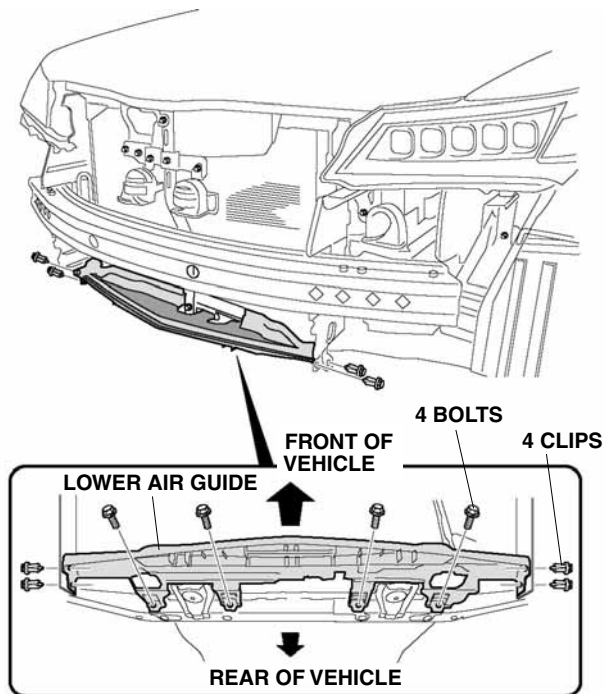

QDD1005AT

4. Remove the front bumper center lower grille:
  - Release 12 retaining tabs.
  - If equipped, remove the vehicle harness clamps.

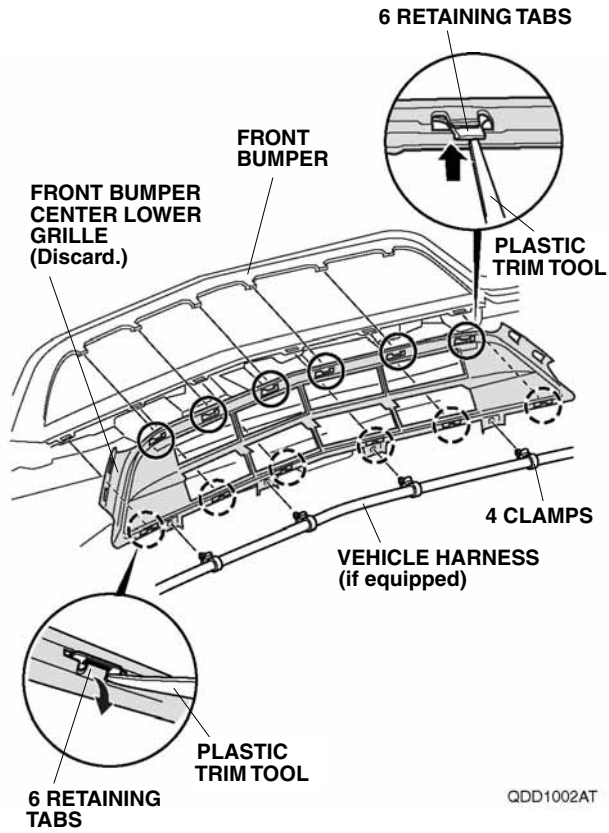

5. Install the accessory front towing grille:
  - If equipped, attach the vehicle harness clamps.

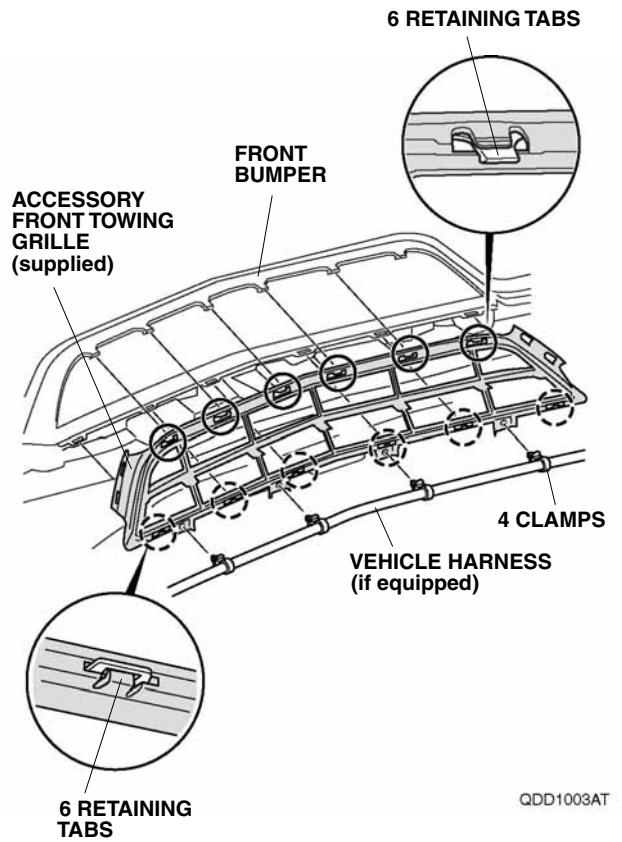

6. Pull each lever, and fold down the left and right third row seats.

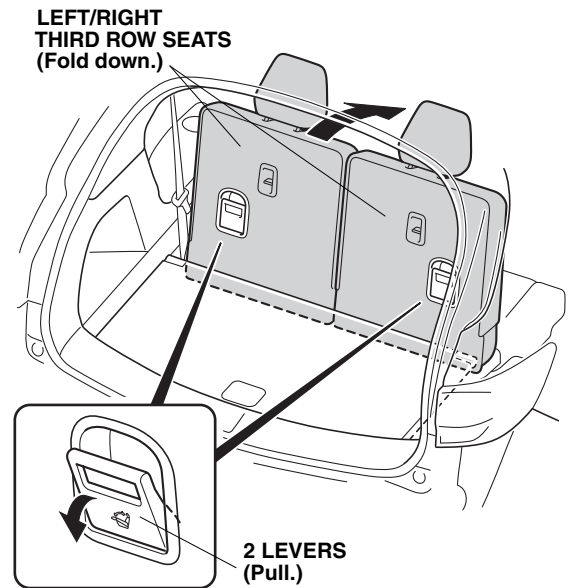

7. Open the cargo lid.

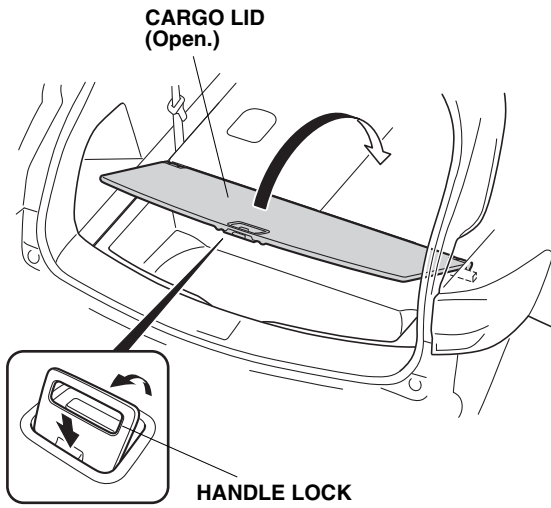

QBN0702AH

8. Remove the cargo lining.

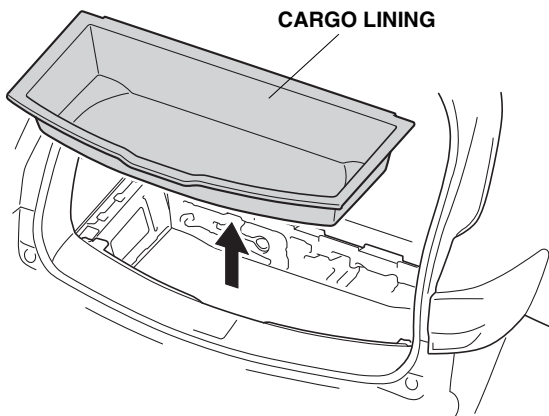

QB01913AH

9. Remove the rear junction box cover.

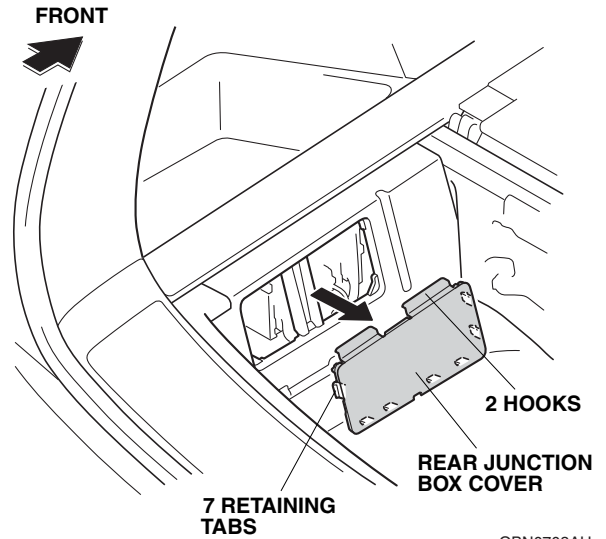

QBN0703AH

→ With spare tire: go to step 10

→ Without spare tire: go to step 11

10. Locate and remove the rubber plug to access the spare tire hoist shaft. Lower the spare tire completely.

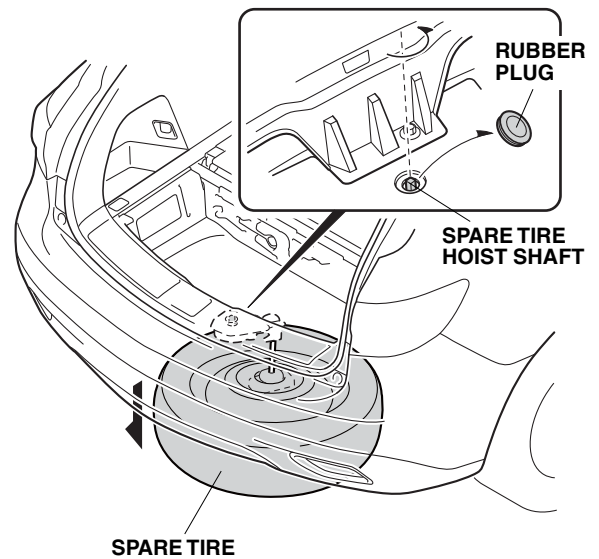

QBN0704AH

- Under the vehicle locate and remove the rear bumper lower face.

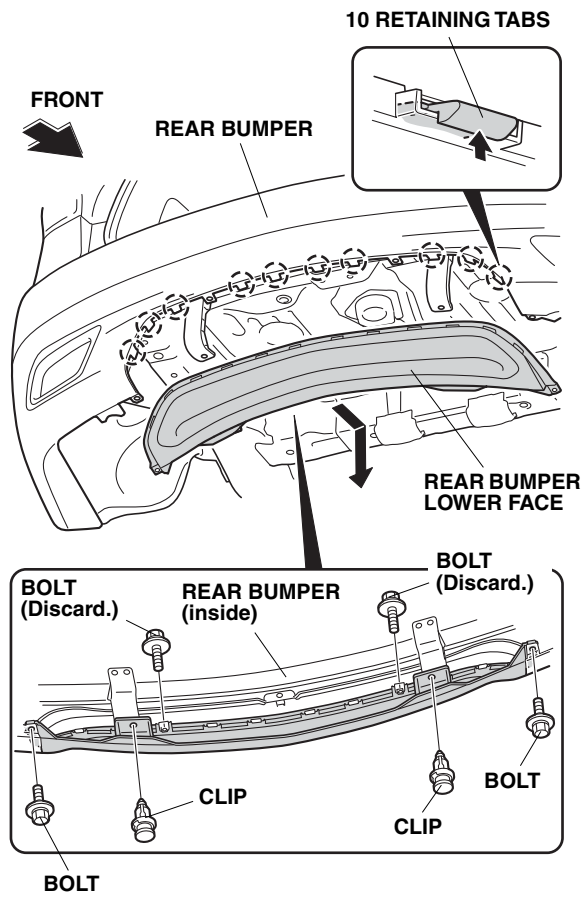

QBN0705AH

### Installing the Trailer Hitch

- Remove the four clip nuts from the rear bumper lower face, and transfer the four clip nuts to the trailer hitch cover.

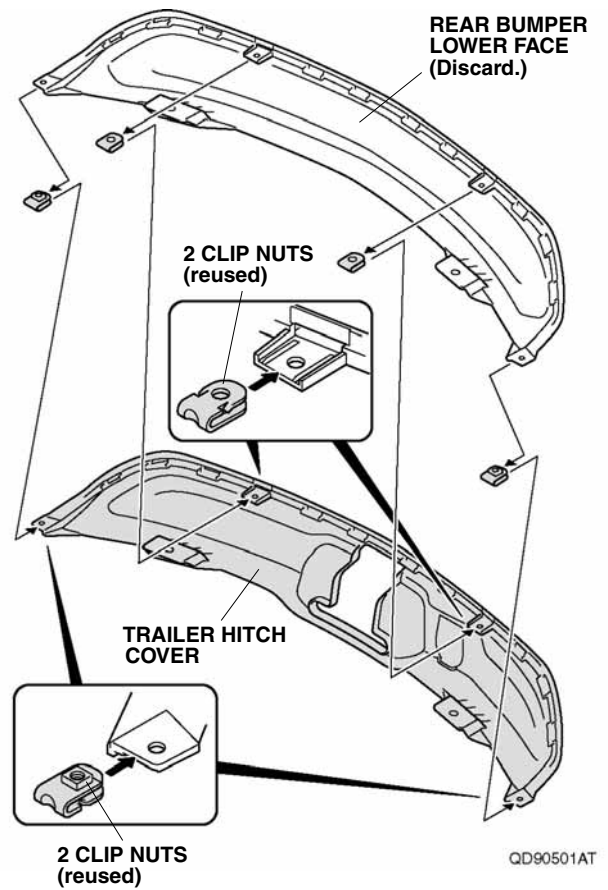

QD90501AT

→ With trailer hitch harness: go to step 13

→ Without trailer hitch harness: go to step 14

- Using a utility knife, cut out the trailer hitch cover in the area shown. Remove any burrs.

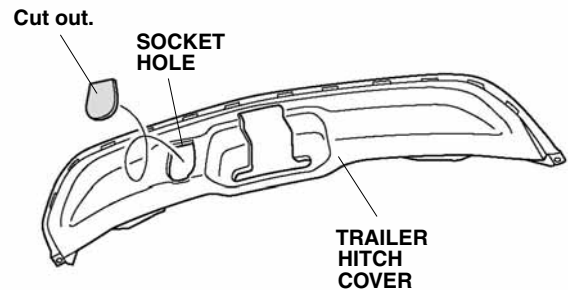

QD90502AT

14. Install the trailer hitch cover to the rear bumper. Secure the cover using the 10 retaining tabs, two 6 x 14 mm washer-bolts included in the kit and the two bolts removed in step 11.

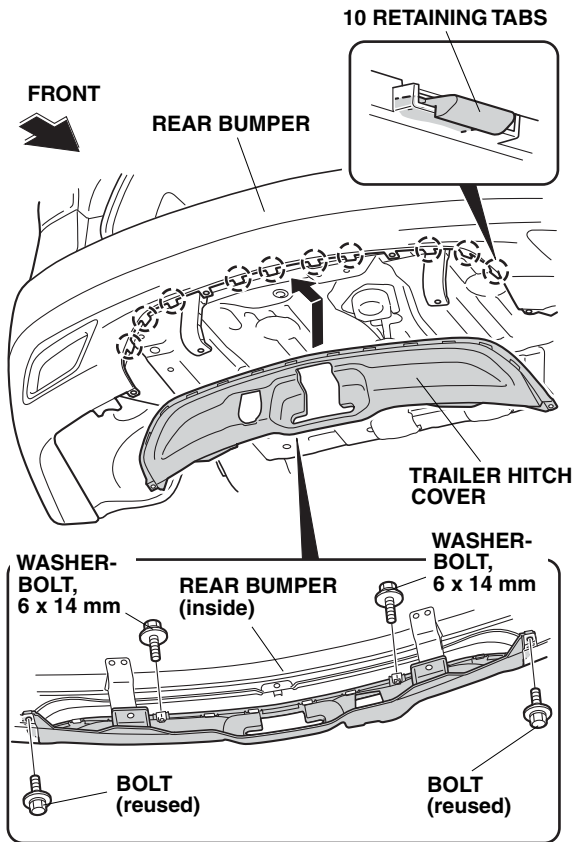

QBN0707BH

→ **With trailer hitch harness: go to step 15**

→ **Without trailer hitch harness: go to step 16**

15. Install the socket harness 7-pin socket to the trailer hitch with one 6 x 16 mm flange bolt, one 6 x 19 mm shoulder bolt, and two flange nuts.

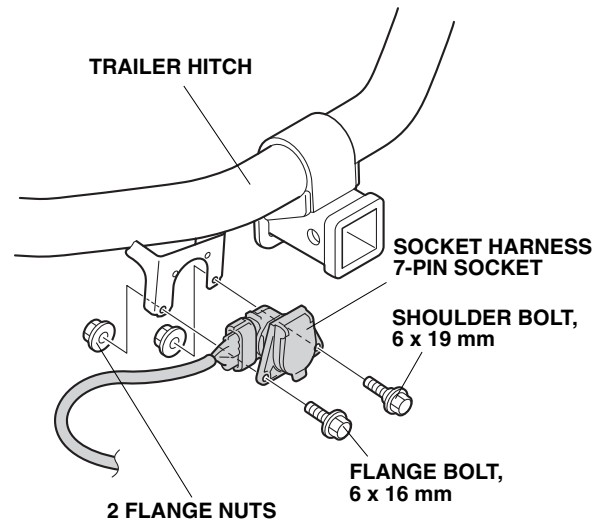

QBN0708CH



- With the help of an assistant, position the trailer hitch on the vehicle and loosely install the six 14 x 40 mm flange bolts.

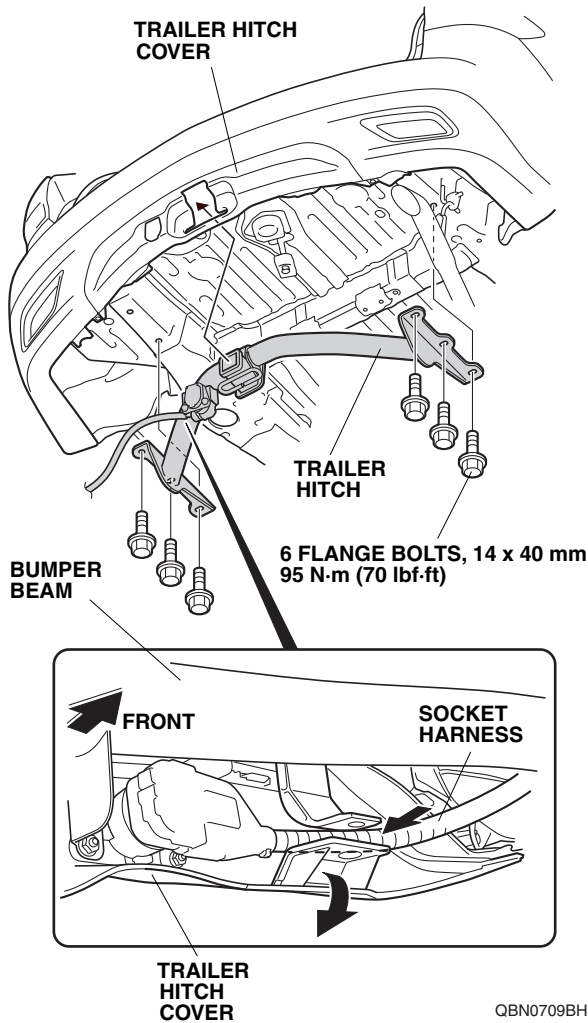

- Torque the six 14 x 40 mm flange bolts to 95 N-m (70 lbf-ft).

- Secure the trailer hitch cover to the bumper beam with two clips removed in step 11.

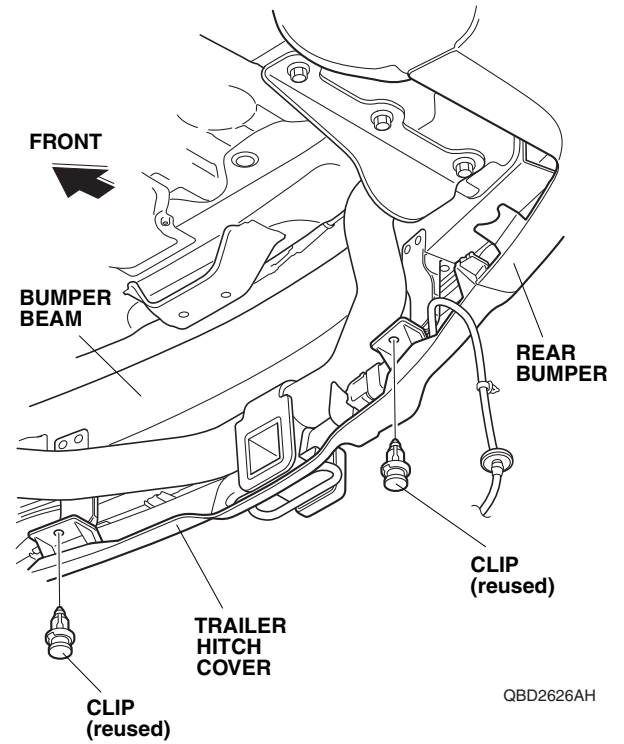

- Using isopropyl alcohol on a shop towel, thoroughly clean the trailer hitch cover where the caution label will attach.

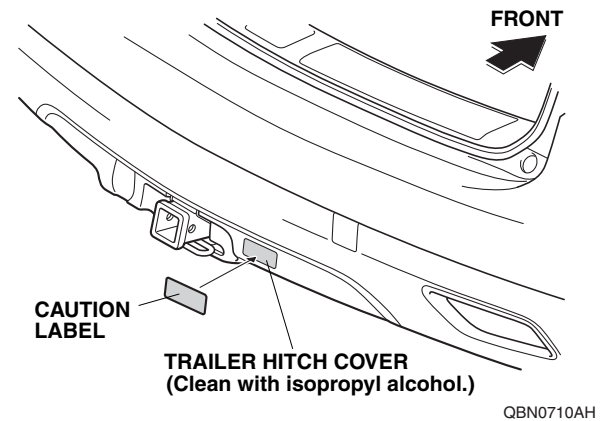

- Attach the caution label to the trailer hitch cover at the area shown.

**Installing the Control Unit and Socket Harnesses**

→ **With trailer hitch harness: go to step 21**

→ **Without trailer hitch harness: go to step 43**

21. Install the control unit bracket to the control unit.

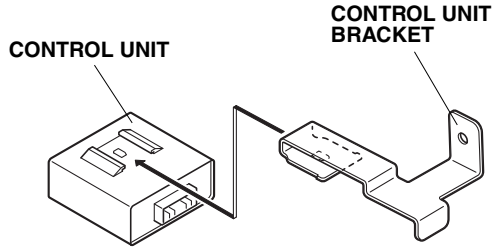

QBN0711AH

22. Using isopropyl alcohol on a shop towel, thoroughly clean the control unit bracket where the urethane tape will attach.

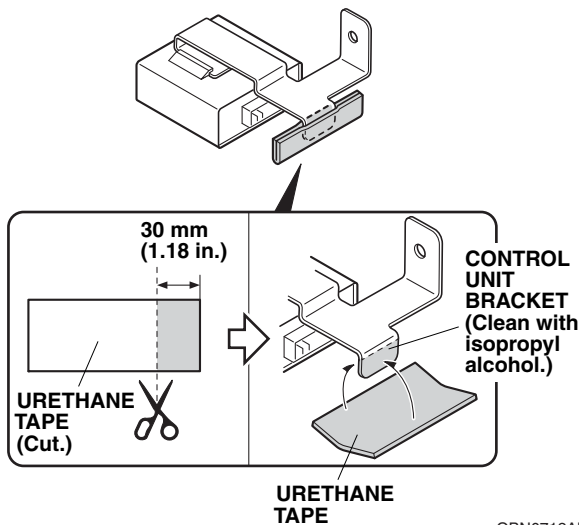

QBN0712AH

23. Using scissors, cut one urethane tape to the measurement shown. Wrap the cut urethane tape to the control unit bracket as shown.

24. Remove the vehicle bolt from the rear junction box. Insert the control unit to the rear junction box lid opening in the direction shown.

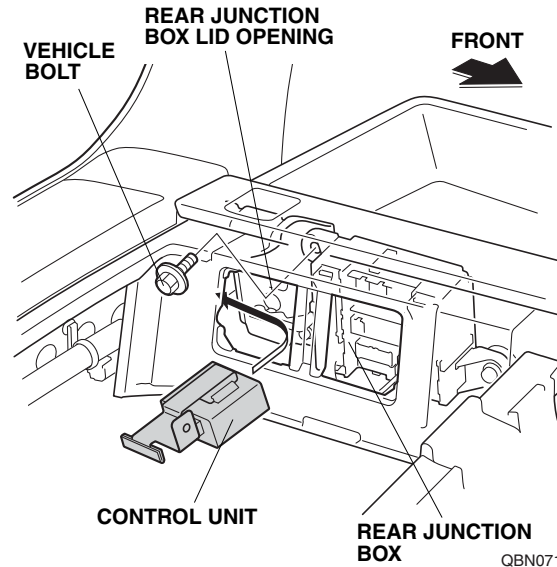

QBN0713AH

25. Position the control unit bracket as shown, and secure the control unit bracket with the vehicle bolt.

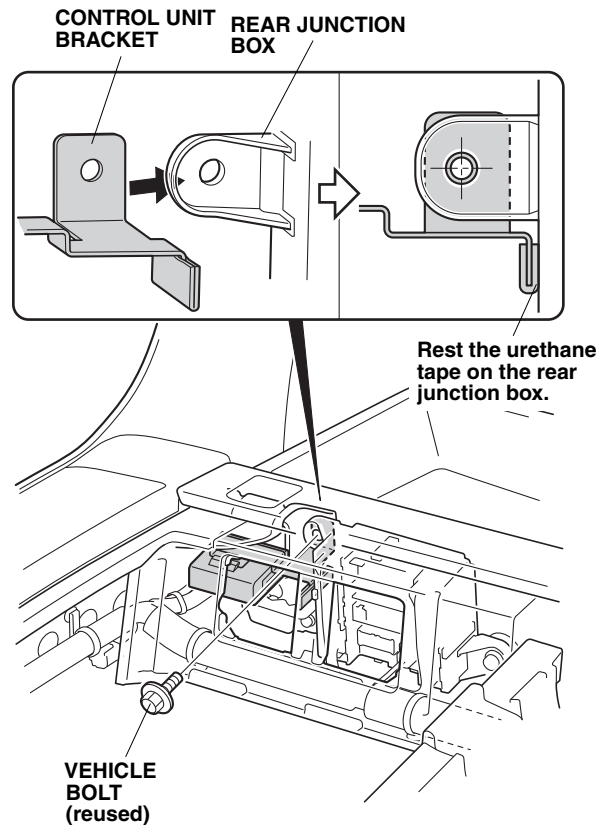

QBN0714AH

- Install the two relays into the control unit harness relay block.

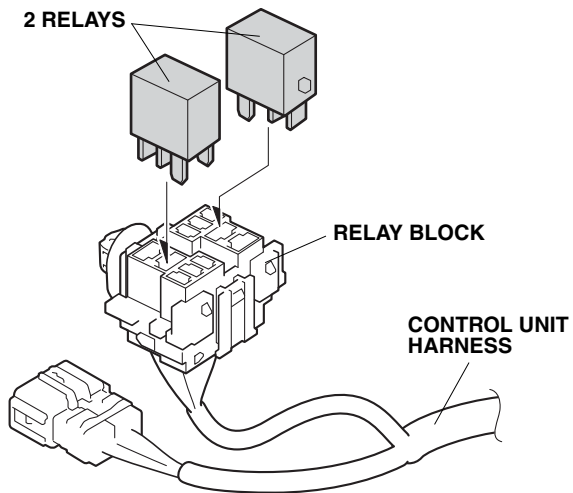

QBN0715AH

- Route the control unit harness along the vehicle harness, and attach the control unit harness relay block to the vehicle panel.

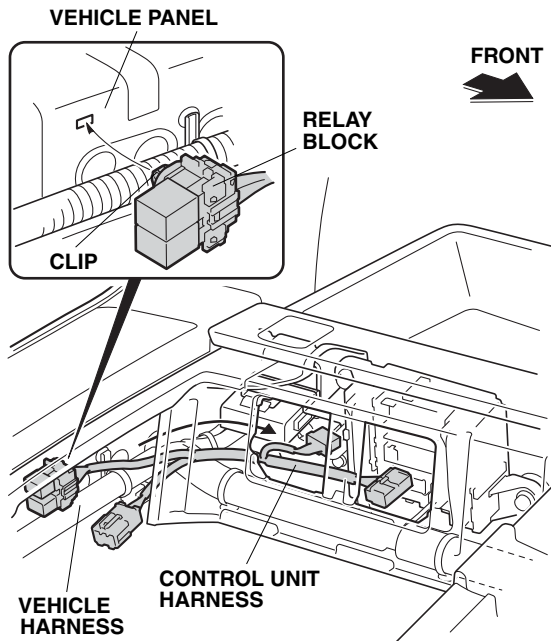

QBN0716AH

- Plug the control unit harness 14-pin connector into the rear junction box 14-pin connector.

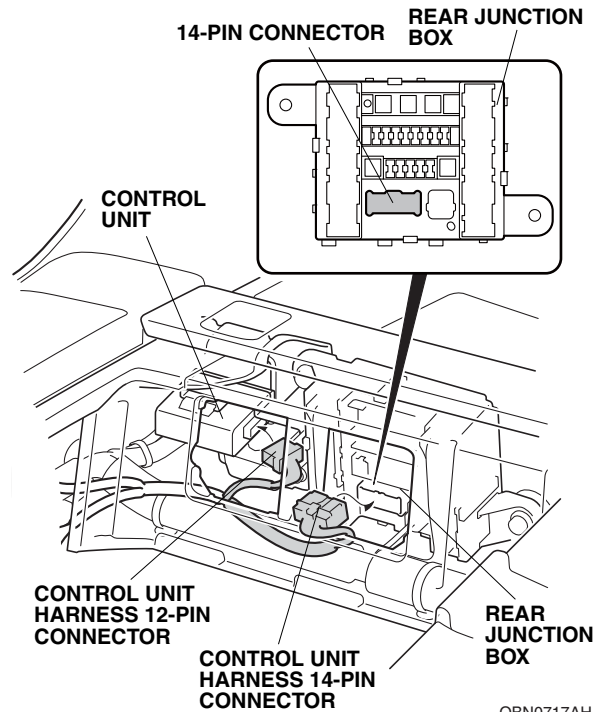

QBN0717AH

- Plug the control unit harness 12-pin connector into the control unit.
- Secure the control unit harness to the vehicle harness with one wire tie.

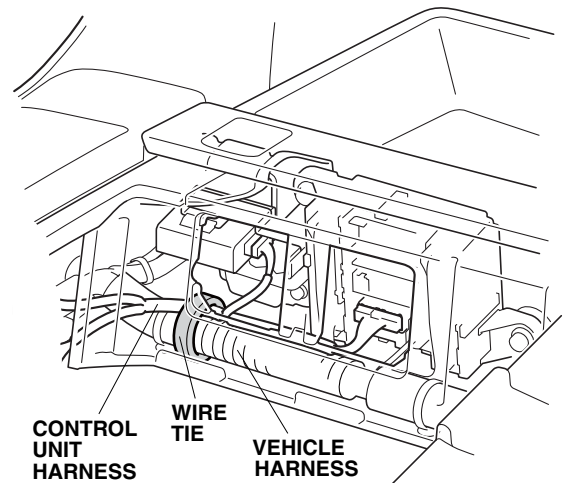

QBN0718AH

31. Under the vehicle, route the socket harness as shown, and secure it to the vehicle bracket with one wire tie.

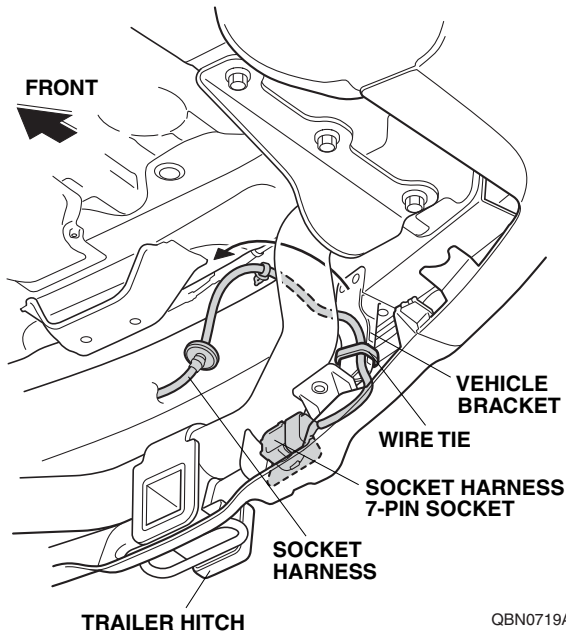

32. Locate and remove the vehicle grommet from the floor panel.

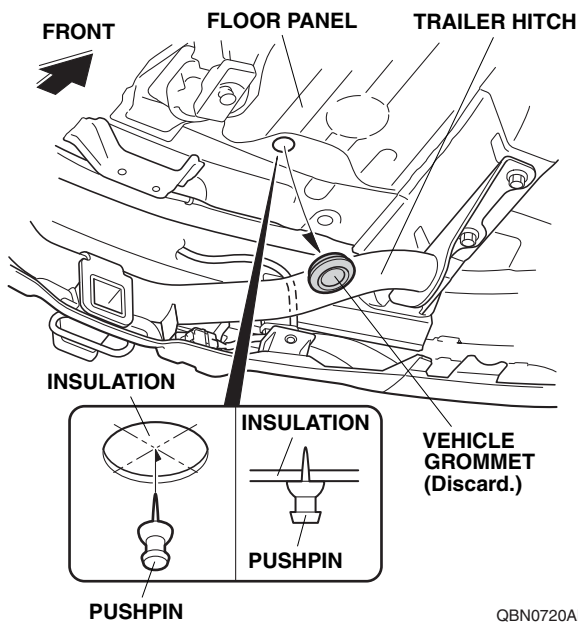

33. Using a pushpin, pierce the insulation.

34. Using a utility knife, cut the insulation at the area shown. Do not damage the floor panel.

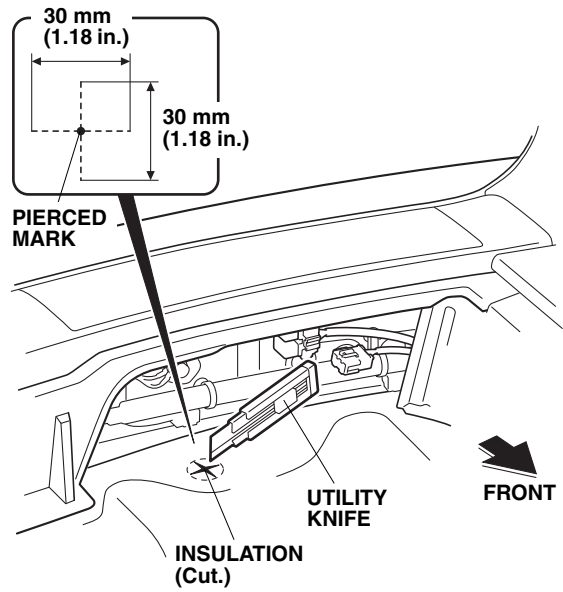

35. Route the socket harness 8-pin connector through the vehicle grommet hole, and seat the socket harness grommet into the vehicle grommet hole. NOTE:

- Install the socket harness by holding the grommet.
- Make sure to check that the grommet is secured properly.

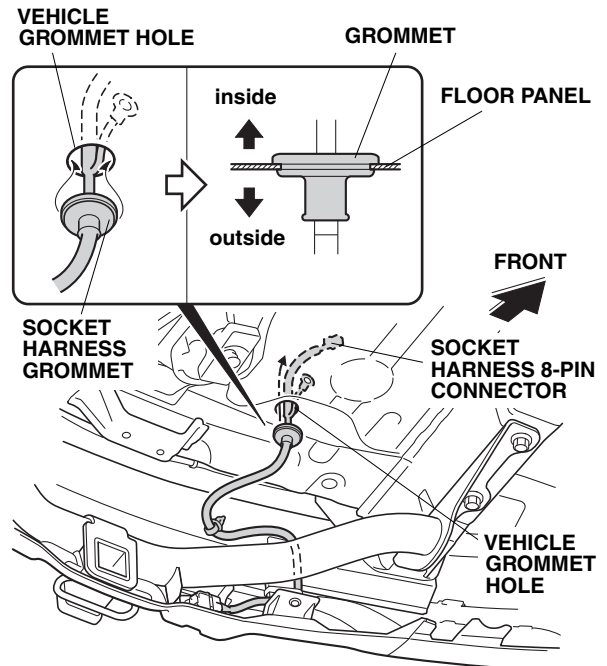

36. Secure the socket harness clip to the vehicle frame.

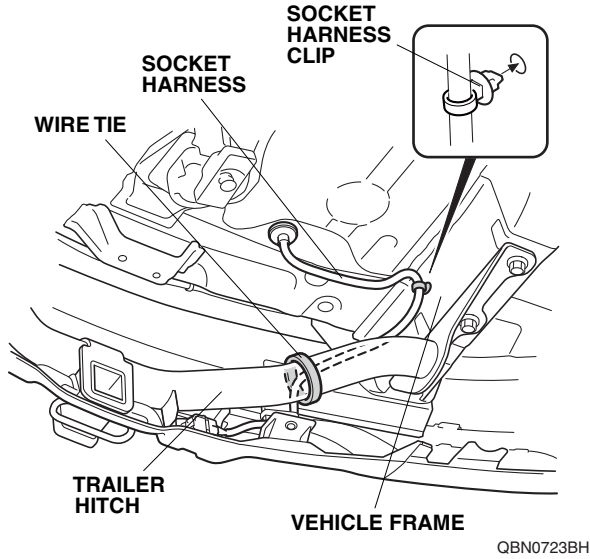

37. Secure the socket harness to the trailer hitch with one wire tie.
38. Remove the vehicle ground bolt. Attach the socket harness ground terminal to the vehicle ground terminal, and reinstall the vehicle ground bolt.

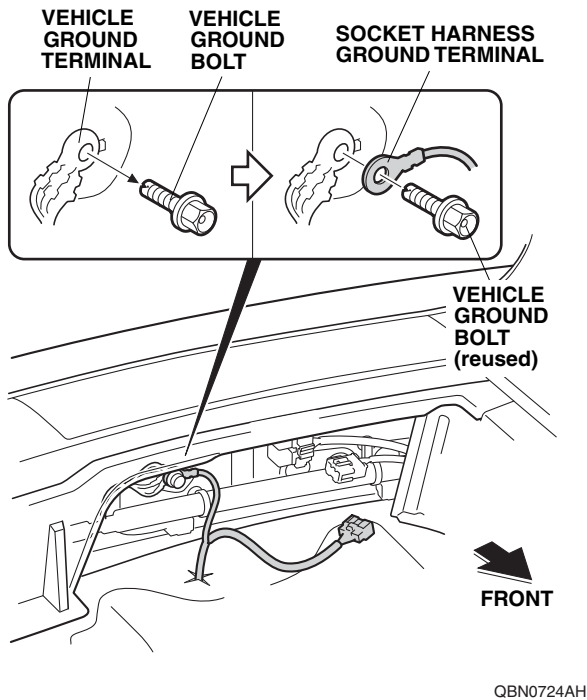

39. Plug the socket harness 8-pin connector into the control unit harness 8-pin connector.

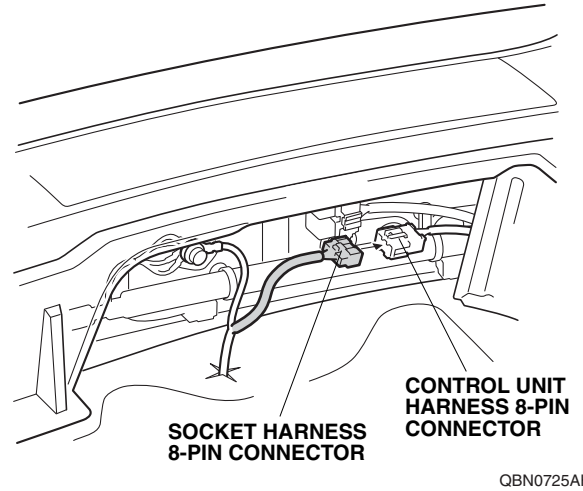

40. Secure the control unit harness 8-pin connector to the vehicle harness with one wire tie.

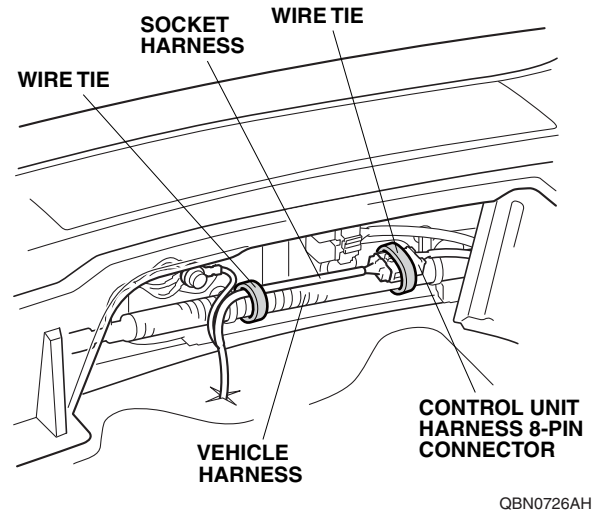

41. Secure the socket harness to the vehicle harness with one wire tie.

42. Plug the two 7.5A blade fuses and the two 20A blade fuses into the rear junction box.

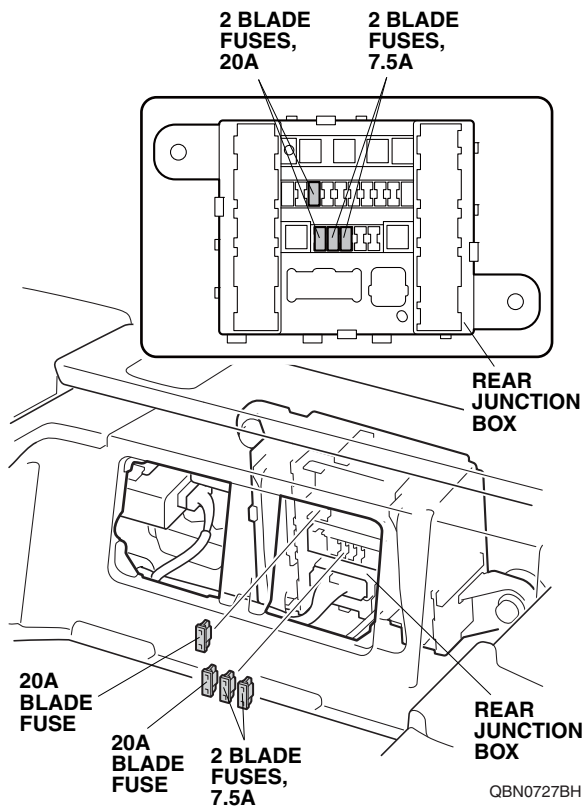

52. Put the 20A block fuse into the subharness kit.

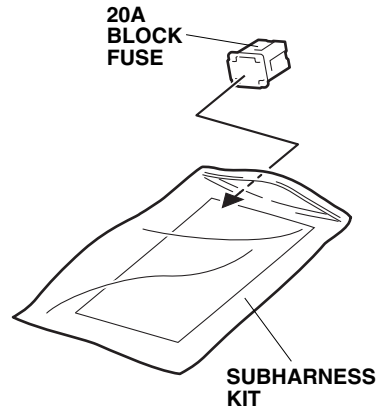

QC21701AH

53. Place the subharness kit into the vehicle glove box.

43. Check that all wire harnesses are routed properly and that all connectors are plugged in.
44. Reinstall all removed parts except for the front bulkhead cover and the intake air tube.
45. Reconnect the negative cable to the battery.
46. Reinstall the front bulkhead cover and the intake air tube.
47. Press and hold the radio power button for two seconds to restore the radio and navi (if equipped) system functions.
48. Reset the clock on vehicles without navigation.
49. Secure the ball mount to the trailer hitch with one hitch pin and the hitch pin clip.
50. Restore the systems back to normal operation as described in the Service Manual if necessary.
51. Refer to the "TRAILER HARNESS TESTER", and perform the "Trailer Harness Circuit Check."

**Give a copy of this page to your client**

Whenever you remove the hitch pin clip, the hitch pin, and the ball mount, store them securely in the cargo area. Install the receiver cover into the opening at the end of the trailer hitch. When you reinstall the ball mount, store the receiver cover in the cargo area.

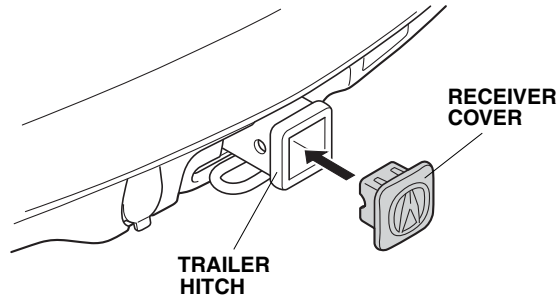

QBN0728AH

Install the ball mount into the trailer hitch using a hitch pin clip and hitch pin.

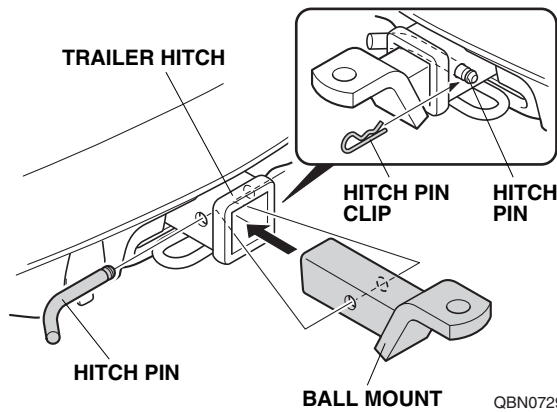

QBN0729AH

After the first 600 miles (1,000 km) of towing, have your Acura Dealer re-check the tightness of the trailer hitch bolts.

### How to Handle Subharness

This subharness is designed for use with the installation of an electric brake controller. Refer to the vehicle Owner's Manual for the detailed information about handling this subharness.

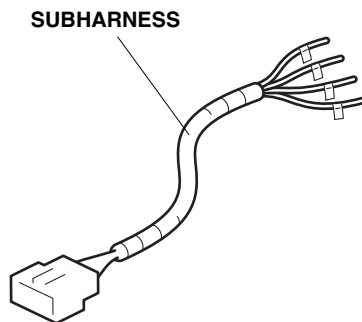

QBN0730AH